

## LM74

# SPI/MICROWIRE™ 12-Bit Plus Sign Temperature Sensor

### General Description

The LM74 is a temperature sensor, Delta-Sigma analog-to-digital converter with an SPI and MICROWIRE compatible interface. The host can query the LM74 at any time to read temperature. A shutdown mode decreases power consumption to less than 10  $\mu$ A. This mode is useful in systems where low average power consumption is critical.

The LM74 has 12-bit plus sign temperature resolution (0.0625°C per LSB) while operating over a temperature range of -55°C to +150°C.

The LM74's 3.0V to 5.5V supply voltage range, low supply current and simple SPI interface make it ideal for a wide range of applications. These include thermal management and protection applications in hard disk drives, printers, electronic test equipment, and office electronics. The LM74 is available in the SO-8 package as well as an 5-Bump micro SMD package.

### Applications

- System Thermal Management
- Personal Computers
- Disk Drives
- Office Electronics

- Electronic Test Equipment

### Features

- 0.0625°C temperature resolution.
- Shutdown mode conserves power between temperature reading
- SPI and MICROWIRE Bus interface
- 5-Bump micro SMD package saves space

### Key Specifications

■ Supply Voltage		3.0V or 2.65V to 5.5V
■ Supply Current	operating	265 $\mu$ A (typ) 520 $\mu$ A (max)
	shutdown	3 $\mu$ A (typ)
■ Temperature Accuracy	-10°C to 65°C	$\pm 1.25^\circ\text{C}(\text{max})$
	-25°C to 110°C	$\pm 2.1^\circ\text{C}(\text{max})$
	-55°C to 125°C	$\pm 3^\circ\text{C}(\text{max})$

### Simplified Block Diagram

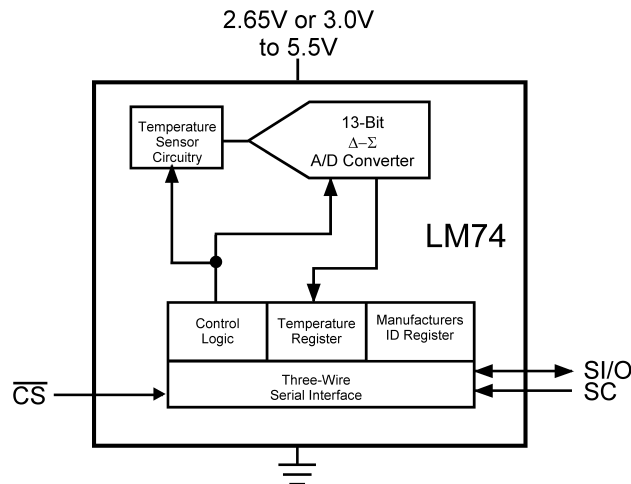

10090901

## Connection Diagrams

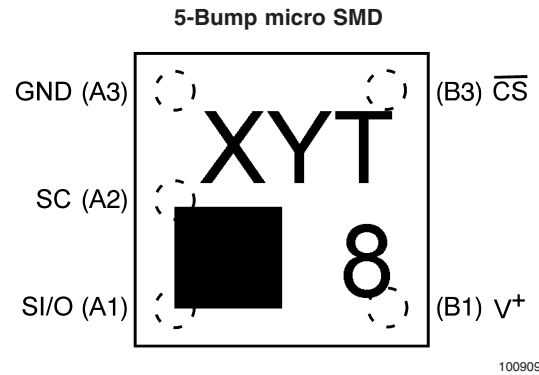
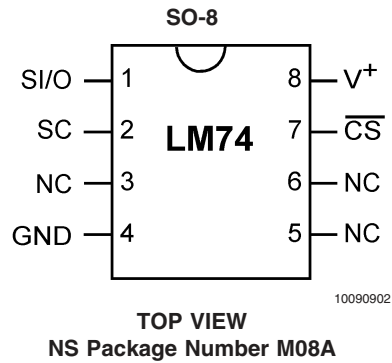

**Note:**

- Pin numbers are referenced to the package marking text orientation. Pin 1 is designated by the square.
- Reference JEDEC Registration MO-211, variation BC
- The top 4 characters designate the date code. The bottom 3 characters designate the device type (see ordering information).

## Ordering Information

Order Number	Package Marking	NS Package Number	Supply Voltage	Transport Media
LM74CIM-3	LM74CIM-3	SO-8, M08A	3.0V to 3.6V	95 Units in Rail
LM74CIMX-3	LM74CIM-3	SO-8, M08A	3.0V to 3.6V	2500 Units in Tape and Reel
LM74CIM-5	LM74CIM-5	SO-8, M08A	4.5V to 5.5V	95 Units in Rail
LM74CIMX-5	LM74CIM-5	SO-8, M08A	4.5V to 5.5V	2500 Units in Tape and Reel
LM74CIBP-3	T8	micro SMD, BPD05MPB	2.65V to 3.6V	250 Units in Tape and Reel
LM74CIBPX-3	T8	micro SMD, BPD05MPB	2.65V to 3.6V	3000 Units in Tape and Reel
LM74CIBP-5	T9	micro SMD, BPD05MPB	4.5V to 5.5V	250 Units in Tape and Reel
LM74CIBPX-5	T9	micro SMD, BPD05MPB	4.5V to 5.5V	3000 Units in Tape and Reel

## Pin Descriptions

Label	SO-8 Pin #	micro SMD Pin #	Function	Typical Connection
SI/O	1	1	Slave Input/Output - Serial bus bi-directional data line. Schmitt trigger input.	From and to Controller
SC	2	5	Slave Clock - Serial bus clock Schmitt trigger input line.	From Controller
NC	3		No Connection	No Connection
GND	4	4	Power Supply Ground	Ground
NC	5		No Connection	No Connection
NC	6		No Connection	No Connection
$\overline{\text{CS}}$	7	3	Chip Select input.	From Controller
V <sup>+</sup>	8	2	Positive Supply Voltage Input	DC Voltage from 3.0V to 5.5V for the LM74CIM and 2.65V to 5.5V for the LM74CIBP. Bypass with a 0.1 $\mu\text{F}$ ceramic capacitor.

## Typical Application

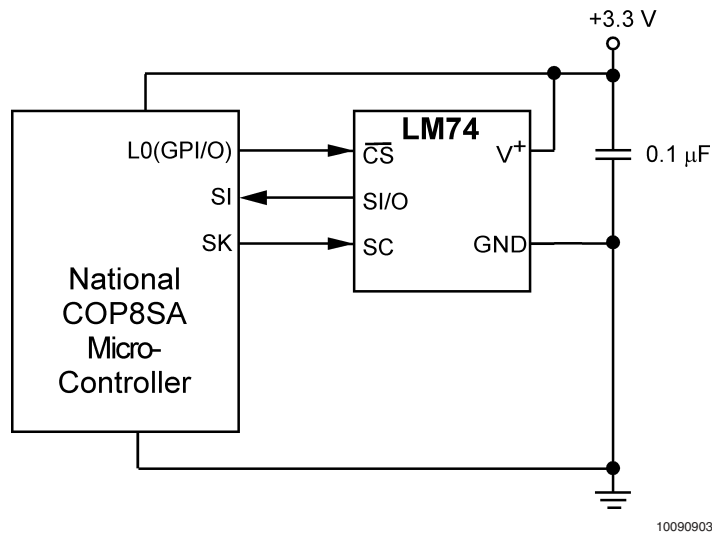

FIGURE 1. COP Microcontroller Interface

**Absolute Maximum Ratings** (Note 1)

Supply Voltage	-0.3V to 6.0V
Voltage at any Pin	-0.3V to $V^+ + 0.3V$
Input Current at any Pin (Note 2)	5 mA
Package Input Current (Note 2)	20 mA
Storage Temperature	-65°C to +150°C
Soldering Information, Lead Temperature	
SO-8 Package (Note 3)	
Vapor Phase (60 seconds)	215°C
Infrared (15 seconds)	220°C
ESD Susceptibility (Note 4)	
Human Body Mode	
LM74CIBP SC, pin 5	1900V

LM74CIM and LM74CIBP all other pins	2000V
Machine Model	200V

**Operating Ratings**

Specified Temperature Range (Note 5)	$T_{MIN}$ to $T_{MAX}$
LM74CIBP	-40°C to +125°C
LM74CIM	-55°C to +150°C
Supply Voltage Range ( $+V_S$ )	
LM74CIBP	+2.65V to +5.5V
LM74CIM	+3.0V to +5.5V

**Temperature-to-Digital Converter Characteristics**

Unless otherwise noted, these specifications apply for  $V^+ = 2.65V$  to  $3.6V$  for the LM74CIBP -3,  $V^+ = 3.0V$  to  $3.6V$  for the LM74CIM -3 and  $V^+ = 4.5V$  to  $5.5V$  for the LM74 -5 (Note 6). **Boldface limits apply for  $T_A = T_J = T_{MIN}$  to  $T_{MAX}$** ; all other limits  $T_A = T_J = +25^\circ C$ , unless otherwise noted.

Parameter	Conditions	Typical (Note 7)	LM74-5 Limits (Note 8)	LM74-3 Limits (Note 8)	Units (Limit)	
Temperature Error (Note 6)	$T_A = -10^\circ C$ to $+65^\circ C$		<b><math>\pm 1.25</math></b>	<b><math>\pm 1.25</math></b>	°C (max)	
	$T_A = -25^\circ C$ to $+110^\circ C$		<b><math>\pm 2.1</math></b>	<b><math>+2.65/-2.15</math></b>	°C (max)	
	$T_A = -40^\circ C$ to $+85^\circ C$		<b><math>+2.65/-1.65</math></b>	<b><math>\pm 2.15</math></b>	°C (max)	
	$T_A = -40^\circ C$ to $+110^\circ C$		<b><math>+2.65/-2.0</math></b>	<b><math>+2.65/-2.15</math></b>	°C (max)	
	$T_A = -55^\circ C$ to $+125^\circ C$		<b><math>\pm 3.0</math></b>	<b><math>\pm 3.5</math></b>	°C (max)	
	$T_A = -55^\circ C$ to $+150^\circ C$		<b><math>\pm 5.0</math></b>	<b><math>\pm 5.0</math></b>	°C (max)	
Resolution		13			Bits	
Temperature Conversion Time	SO-8 (Note 9)	280	<b>425</b>	<b>425</b>	ms (max)	
	micro SMD (Note 9)	611	<b>925</b>	<b>925</b>	ms (max)	
Quiescent Current	SO-8	Serial Bus Inactive	310	<b>520</b>	<b>520</b>	$\mu A$ (max)
			micro SMD	265	<b>470</b>	<b>470</b>
	SO-8	Serial Bus Active	310			$\mu A$
			micro SMD	310		
	SO-8	Shutdown Mode, $V^+ = 3.3V$	7			$\mu A$
			micro SMD	3		
	SO-8	Shutdown Mode, $V^+ = 5V$	8			$\mu A$
			micro SMD	4		

**Logic Electrical Characteristics**

**DIGITAL DC CHARACTERISTICS** Unless otherwise noted, these specifications apply for  $V^+ = 2.65V$  to  $3.6V$  for the LM74CIBP -3,  $V^+ = 3.0V$  to  $3.6V$  for the LM74CIM -3 and  $V^+ = 4.5V$  to  $5.5V$  for the LM74 -5 (Note 6). **Boldface limits apply for  $T_A = T_J = T_{MIN}$  to  $T_{MAX}$** ; all other limits  $T_A = T_J = +25^\circ C$ , unless otherwise noted.

Symbol	Parameter	Conditions	Typical (Note 7)	Limits (Note 8)	Units (Limit)
$V_{IN(1)}$	Logical "1" Input Voltage			<b><math>V^+ \times 0.7</math></b>	V (min)
				<b><math>V^+ + 0.3</math></b>	V (max)
$V_{IN(0)}$	Logical "0" Input Voltage			<b>-0.3</b>	V (min)
				<b><math>V^+ \times 0.3</math></b>	V (max)
	Input Hysteresis Voltage	$V^+ = 3.0V$ to $3.6V$	0.8	<b>0.35</b>	V (min)
		$V^+ = 4.5V$ to $5.5V$	0.8	<b>0.33</b>	V (min)
$I_{IN(1)}$	Logical "1" Input Current	$V_{IN} = V^+$	0.005	<b>3.0</b>	$\mu A$ (max)

## Logic Electrical Characteristics (Continued)

**DIGITAL DC CHARACTERISTICS** Unless otherwise noted, these specifications apply for  $V^+ = 2.65\text{V}$  to  $3.6\text{V}$  for the LM74CIBP -3,  $V^+ = 3.0\text{V}$  to  $3.6\text{V}$  for the LM74CIM -3 and  $V^+ = 4.5\text{V}$  to  $5.5\text{V}$  for the LM74 -5 (Note 6). **Boldface limits apply for  $T_A = T_J = T_{\text{MIN}}$  to  $T_{\text{MAX}}$** ; all other limits  $T_A = T_J = +25^\circ\text{C}$ , unless otherwise noted.

Symbol	Parameter	Conditions	Typical (Note 7)	Limits (Note 8)	Units (Limit)
$I_{\text{IN}(0)}$	Logical "0" Input Current	$V_{\text{IN}} = 0\text{V}$	-0.005	<b>-3.0</b>	$\mu\text{A}$ (min)
$C_{\text{IN}}$	All Digital Inputs		20		pF
$V_{\text{OH}}$	High Level Output Voltage	$I_{\text{OH}} = -400\ \mu\text{A}$		<b>2.4</b>	V (min)
$V_{\text{OL}}$	Low Level Output Voltage	$I_{\text{OL}} = +2\ \text{mA}$		<b>0.4</b>	V (max)
$I_{\text{O\_TRI-STATE}}$	TRI-STATE Output Leakage Current	$V_{\text{O}} = \text{GND}$ $V_{\text{O}} = V^+$		<b>-1</b>	$\mu\text{A}$ (min)
				<b>+1</b>	$\mu\text{A}$ (max)

**SERIAL BUS DIGITAL SWITCHING CHARACTERISTICS** Unless otherwise noted, these specifications apply for  $V^+ = 2.65\text{V}$  to  $3.6\text{V}$  for the LM74CIBP -3,  $V^+ = 3.0\text{V}$  to  $3.6\text{V}$  for the LM74CIM -3 and  $V^+ = 4.5\text{V}$  to  $5.5\text{V}$  for the LM74 -5 (Note 6);  $C_L$  (load capacitance) on output lines =  $100\ \text{pF}$  unless otherwise specified. **Boldface limits apply for  $T_A = T_J = T_{\text{MIN}}$  to  $T_{\text{MAX}}$** ; all other limits  $T_A = T_J = +25^\circ\text{C}$ , unless otherwise noted.

Symbol	Parameter	Conditions	Typical (Note 7)	Limits (Note 8)	Units (Limit)
$t_1$	SC (Clock) Period			<b>0.16</b> DC	$\mu\text{s}$ (min) (max)
$t_2$	$\overline{\text{CS}}$ Low to SC (Clock) High Set-Up Time			<b>100</b>	ns (min)
$t_3$	$\overline{\text{CS}}$ Low to Data Out (SO) Delay			<b>70</b>	ns (max)
$t_4$	SC (Clock) Low to Data Out (SO) Delay			<b>100</b>	ns (max)
$t_5$	$\overline{\text{CS}}$ High to Data Out (SO) TRI-STATE			<b>200</b>	ns (max)
$t_6$	SC (Clock) High to Data In (SI) Hold Time			<b>50</b>	ns (min)
$t_7$	Data In (SI) Set-Up Time to SC (Clock) High			<b>30</b>	ns (min)

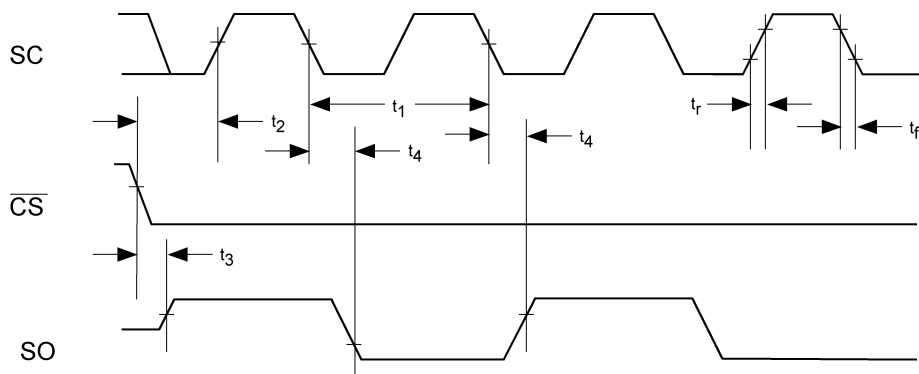

10090904

FIGURE 2. Data Output Timing Diagram

## Logic Electrical Characteristics (Continued)

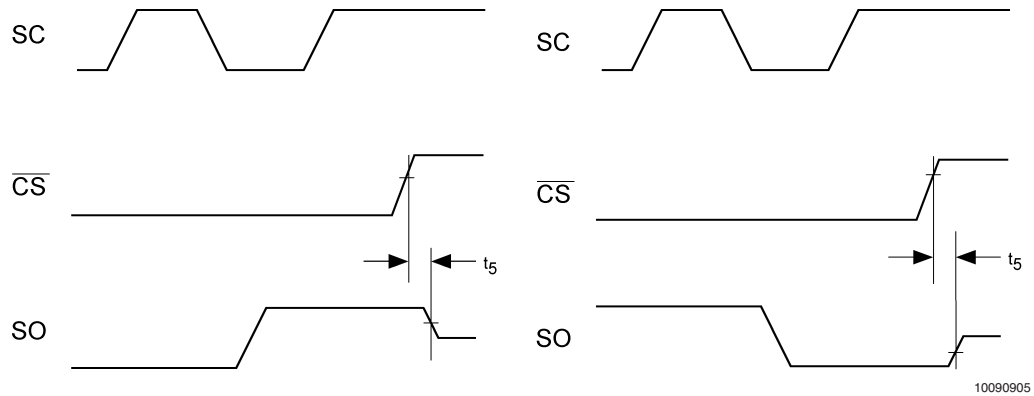

FIGURE 3. TRI-STATE Data Output Timing Diagram

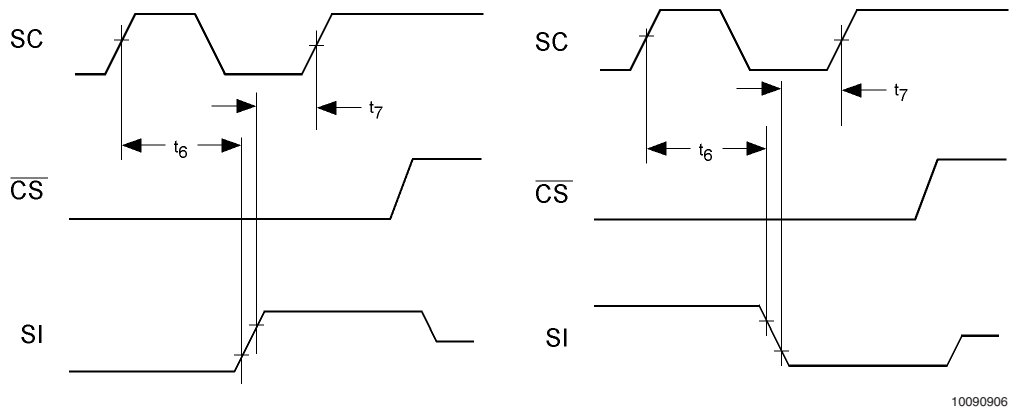

FIGURE 4. Data Input Timing Diagram

**Note 1:** Absolute Maximum Ratings indicate limits beyond which damage to the device may occur. DC and AC electrical specifications do not apply when operating the device beyond its rated operating conditions.

**Note 2:** When the input voltage ( $V_I$ ) at any pin exceeds the power supplies ( $V_I < \text{GND}$  or  $V_I > +V_S$ ) the current at that pin should be limited to 5 mA. The 20 mA maximum package input current rating limits the number of pins that can safely exceed the power supplies with an input current of 5 mA to four.

**Note 3:** See AN-450 "Surface Mounting Methods and Their Effect on Product Reliability" or the section titled "Surface Mount" found in a current National Semiconductor Linear Data Book for other methods of soldering surface mount devices.

**Note 4:** Human body model, 100 pF discharged through a 1.5 k $\Omega$  resistor. Machine model, 200 pF discharged directly into each pin.

**Note 5:** The life expectancy of the LM74 will be reduced when operating at elevated temperatures. LM74  $\theta_{JA}$  (thermal resistance, junction-to-ambient) when attached to a printed circuit board with 2 oz. foil is summarized in the table below:

Device Number	NS Package Number	Thermal Resistance ( $\theta_{JA}$ )
LM74CIM	M08A	160°C/W
LM74CIBP	BPD05MPB	250°C/W

**Note 6:** All SOP (LM74CIM) parts will function over the  $V^+$  supply voltage range of 3V to 5.5V. All micro SMD (LM74SIBP) parts will function over the  $V^+$  supply voltage range of 2.65V to 5.5V. The SOP (LM74CIM) parts are tested and specified for rated temperature error at their nominal supply voltage for temperature ranges of  $-10^\circ\text{C}$  to  $+65^\circ\text{C}$ ,  $-55^\circ\text{C}$  to  $+125^\circ\text{C}$  and  $-55^\circ\text{C}$  to  $+150^\circ\text{C}$ . For the SOP (LM74CIM) parts the temperature error specifications for temperature ranges of  $-40^\circ\text{C}$  to  $+85^\circ\text{C}$ ,  $-25^\circ\text{C}$  to  $+110^\circ\text{C}$  and  $-40^\circ\text{C}$  to  $+110^\circ\text{C}$  include error induced by power supply variation of  $\pm 5\%$  from the nominal value. For the LM74CIM (SOP) parts the temperature error will increase by  $\pm 0.3^\circ\text{C}$  for a power supply voltage ( $V^+$ ) variation of  $\pm 10\%$  from the nominal value.

For the LM74CIBP-3 (micro SMD) parts all accuracies are guaranteed over the supply range of 2.65V to 3.6V, except for the temperature ranges of  $-55^\circ\text{C}$  to  $125^\circ\text{C}$  and  $-55^\circ\text{C}$  to  $+150^\circ\text{C}$  where the accuracy applies for the nominal supply voltage of 3.3V. For the LM74CIBP-5 (micro SMD) parts all accuracies are guaranteed over the supply range of 4.75V to 5.25V, except for the temperature ranges of  $-55^\circ\text{C}$  to  $125^\circ\text{C}$  and  $-55^\circ\text{C}$  to  $+150^\circ\text{C}$  where the accuracy applies for the nominal supply voltage of 5.0V. For the LM74CIBP over  $-55^\circ\text{C}$  to  $125^\circ\text{C}$  and  $-55^\circ\text{C}$  to  $+150^\circ\text{C}$ , a power supply variation of  $\pm 10\%$  will degrade the accuracy by  $\pm 0.3^\circ\text{C}$ .

## Logic Electrical Characteristics (Continued)

**Note 7:** Typical values are at  $T_A = 25^\circ\text{C}$  and represent most likely parametric norm.

**Note 8:** Limits are guaranteed to National's AOQL (Average Outgoing Quality Level).

**Note 9:** This specification is provided only to indicate how often temperature data is updated. The LM74 can be read at any time without regard to conversion state (and will yield last conversion result). A conversion in progress will not be interrupted. The output shift register will be updated at the completion of the read and a new conversion restarted.

**Note 10:** For best accuracy, minimize output loading. Higher sink currents can affect sensor accuracy with internal heating. This can cause an error of  $0.64^\circ\text{C}$  at full rated sink current and saturation voltage based on junction-to-ambient thermal resistance.

## Electrical Characteristics

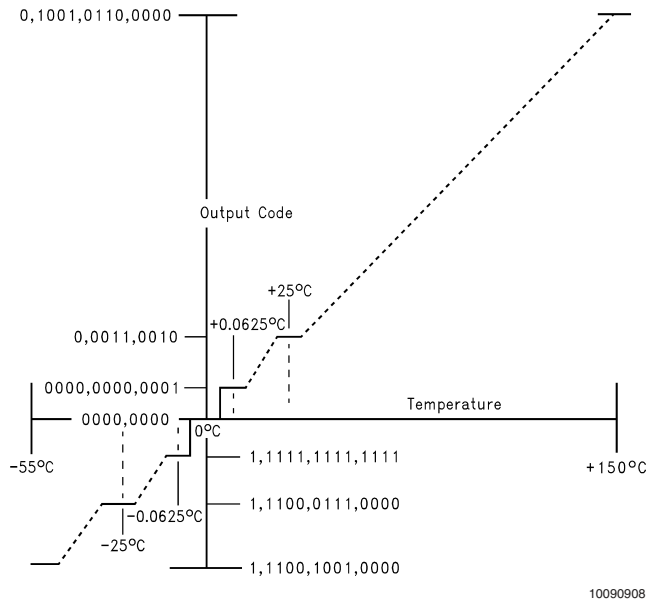

FIGURE 5. Temperature-to-Digital Transfer Function (Non-linear scale for clarity)

## TRI-STATE Test Circuit

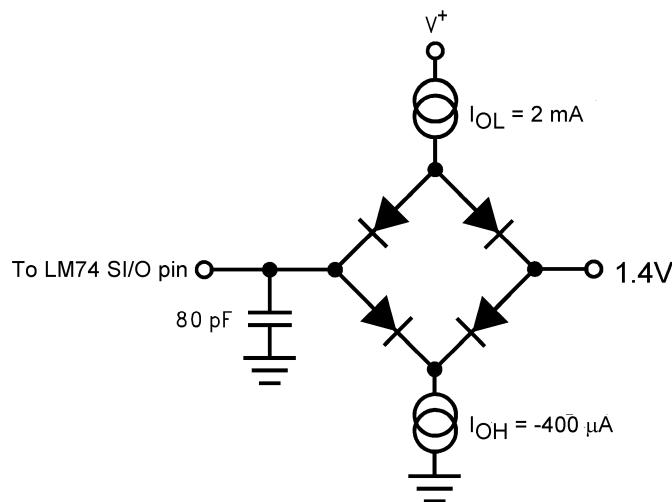
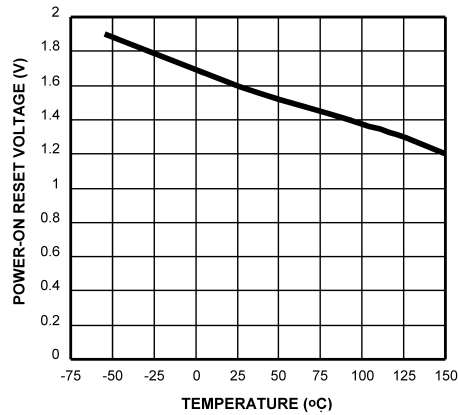

FIGURE 6.

## Typical Performance Characteristics

Average Power-On Reset Voltage vs Temperature



10090923

Static Supply Current vs Temperature (SO-8)

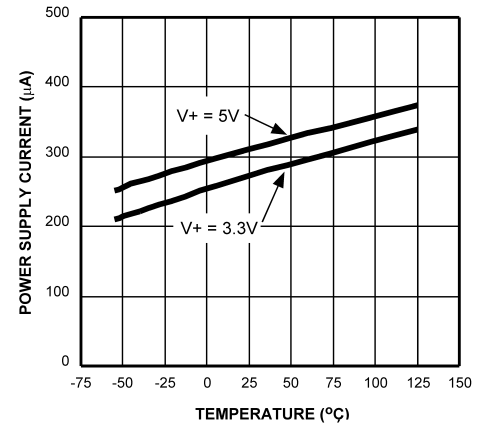

10090921

Static Supply Current vs Temperature (micro SMD)

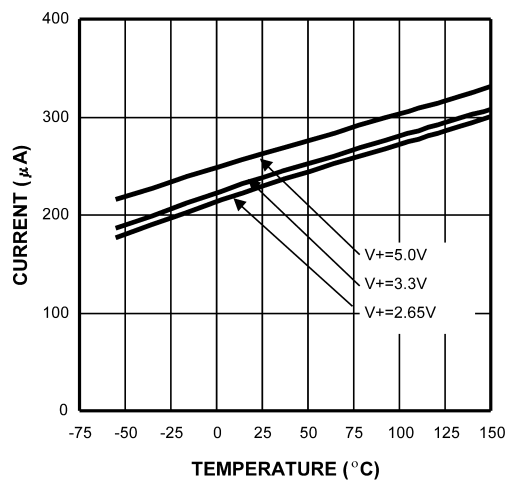

10090925

Temperature Error (SO-8)

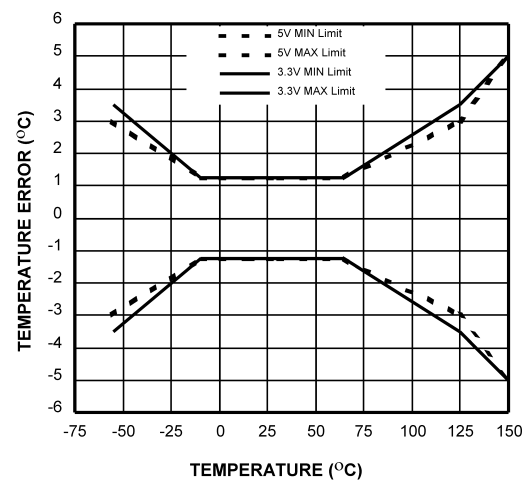

10090922

## 1.0 Functional Description

The LM74 temperature sensor incorporates a band-gap type temperature sensor and 12-bit plus sign  $\Delta\Sigma$  ADC (Delta-Sigma Analog-to-Digital Converter). Compatibility of the LM74's three wire serial interface with SPI and MICROWIRE allows simple communications with common microcontrollers and processors. Shutdown mode can be used to optimize current drain for different applications. A Manufacture's/Device ID register identifies the LM74 as National Semiconductor product.

### 1.1 POWER UP AND POWER DOWN

When the supply voltage is less than about 1.6V (typical), the LM74 is considered powered down. The LM74 always powers up in a known state. When the supply voltage rises above 1.6V (typical), an internal Power-On Reset (POR) occurs and the temperature register will then contain a value of 1111 1111 0000 00XX, where XX indicates undefined values. See Section 1.5.2 for a diagram of the Temperature Register contents after POR but before completion of the first temperature conversion.

The LM74 power-up default condition is continuous conversion mode. After completion of the first full temperature

conversion, the register will contain temperature measurement data in bits D15 (the temperature data MSB) through D3 (the temperature data LSB). Bit D2 will be fixed high; bits D1 and D0 are undefined. See Section 1.5.3 for a diagram of the Temperature Register contents after the first complete temperature conversion. Note that bit D2 represents a complete conversion flag. During POR it is low and, after the first temperature conversion is complete, it goes high. This bit can be polled to indicate when the POR data in the Temperature Register has been replaced with valid temperature data.

After the first conversion, and any subsequent conversions, the value in the temperature register does not change until the completion of the next conversion, at which time the temperature register is updated with the latest temperature value.

### 1.2 SERIAL BUS INTERFACE

The LM74 operates as a slave and is compatible with SPI or MICROWIRE bus specifications. Data is clocked out on the falling edge of the serial clock (SC), while data is clocked in on the rising edge of SC. A complete transmit/receive com-



## 1.0 Functional Description (Continued)

munication will consist of 32 serial clocks. The first 16 clocks comprise the transmit phase of communication, while the second 16 clocks are the receive phase.

When  $\overline{CS}$  is high S/I/O will be in TRI-STATE®. Communication should be initiated by taking chip select ( $\overline{CS}$ ) low. This should not be done when SC is changing from a low to high state. Once  $\overline{CS}$  is low the serial I/O pin (S/I/O) will transmit the first bit of data. The master can then read this bit with the rising edge of SC. The remainder of the data will be clocked out by the falling edge of SC. Once the 14 bits of data (one sign bit, twelve temperature bits and 1 high bit) are transmitted the S/I/O line will go into TRI-STATE.  $\overline{CS}$  can be taken high at any time during the transmit phase. If  $\overline{CS}$  is brought low in the middle of a conversion the LM74 will complete the conversion and the output shift register will be updated after  $\overline{CS}$  is brought back high.

The receive phase of a communication starts after 16 SC periods.  $\overline{CS}$  can remain low for 32 SC cycles. The LM74 will read the data available on the S/I/O line on the rising edge of the serial clock. Input data is to an 8-bit shift register. The part will detect the last eight bits shifted into the register. The receive phase can last up to 16 SC periods. All ones must be shifted in order to place the part into shutdown. A zero in any location will take the LM74 out of shutdown. The following codes should only be transmitted to the LM74:

- 00 hex
- 01 hex
- 03 hex
- 07 hex
- 0F hex
- 1F hex
- 3F hex
- 7F hex
- FF hex

any others may place the part into a Test Mode. Test Modes are used by National Semiconductor to thoroughly test the function of the LM74 during production testing. Only eight bits have been defined above since only the last eight transmitted are detected by the LM74, before  $\overline{CS}$  is taken HIGH.

The following communication can be used to determine the Manufacturer's/Device ID and then immediately place the part into continuous conversion mode. With  $\overline{CS}$  continuously low:

- Read 16 bits of temperature data
- Write 16 bits of data commanding shutdown
- Read 16 bits of Manufacturer's/Device ID data
- Write 8 to 16 bits of data commanding Conversion Mode
- Take  $\overline{CS}$  HIGH.

Note that one complete temperature conversion period will have to pass before the LM74 Temperature register will contain the new temperature data. Until then, it will contain a "stale" temperature (the data that was in the register before going into shutdown mode).

### 1.3 TEMPERATURE DATA FORMAT

Temperature data is represented by a 13-bit, two's complement word with an LSB (Least Significant Bit) equal to 0.0625°C:

Temperature	Digital Output	
	Binary	Hex
+150°C	0100 1011 0000 0111	4B 07h
+125°C	0011 1110 1000 0111	3E 87h
+25°C	0000 1100 1000 0111	0C 87h
+0.0625°C	0000 0000 0000 1111	00 0Fh
0°C	0000 0000 0000 0111	00 07h
-0.0625°C	1111 1111 1111 1111	FF FFh
-25°C	1111 0011 1000 0111	F3 87h
-55°C	1110 0100 1000 0111	E4 87h

Note: The last two bits are TRI-STATE® and depicted as one in the table.

The first data byte is the most significant byte with most significant bit first, permitting only as much data as necessary to be read to determine temperature condition. For instance, if the first four bits of the temperature data indicate an overtemperature condition, the host processor could immediately take action to remedy the excessive temperatures.

### 1.4 SHUTDOWN MODE/MANUFACTURER'S ID

Shutdown mode is enabled by writing XX FF to the LM74 as shown in *Figure 7c*. The serial bus is still active when the LM74 is in shutdown. Current draw drops to less than 10  $\mu$ A between serial communications. When in shutdown mode the LM74 always will output 1000 0000 0000 00XX. This is the manufacturer's/Device ID information. The first 5-bits of the field (1000 0XXX) are reserved for manufacturer's ID. As mentioned in Section 1.2, writing a zero to the LM74 configuration register will take it out of shutdown mode and place it in conversion mode. In other words, any valid code listed in Section 1.2 other than XX FF will put it in conversion mode. After leaving shutdown, but before the first temperature conversion is complete, the temperature register will contain the last measured temperature which resided in the temperature register before entering shutdown mode. After the completion of the first conversion, the temperature register will be updated with the new temperature data.

## 1.0 Functional Description (Continued)

### 1.5 INTERNAL REGISTER STRUCTURE

The LM74 has three registers, the temperature register, the configuration register and the manufacturer's/device identification register. The temperature and manufacturer's/device identification registers are read only. The configuration register is write only.

#### 1.5.1 Configuration Register

(Selects shutdown or continuous conversion modes):

(Write Only):

D15	D14	D13	D12	D11	D10	D9	D8	D7	D6	D5	D4	D3	D2	D1	D0
X	X	X	X	X	X	X	X	Shutdown							

D0–D15 set to XX FF hex enables shutdown mode.

D0–D15 set to 00 00 hex sets Continuous conversion mode.

Note: setting D0-D15 to any other values may place the LM74 into a manufacturer's test mode, upon which the LM74 will stop responding as described. These test modes are to be used for National Semiconductor production testing only. See Section 1.2 Serial Bus Interface for a complete discussion.

#### 1.5.2 Temperature Register (after power-up, before first complete temperature conversion)

(Read Only):

D15	D14	D13	D12	D11	D10	D9	D8	D7	D6	D5	D4	D3	D2	D1	D0
1	1	1	1	1	1	1	1	0	0	0	0	0	0	X	X

D0–D1: Undefined. TRI-STATE will be output on SI/0.

D2–D15: Power-on Reset (POR) values.

#### 1.5.3 Temperature Register (after completion of first temperature conversion)

(Read Only):

D15	D14	D13	D12	D11	D10	D9	D8	D7	D6	D5	D4	D3	D2	D1	D0
MSB	Bit 11	Bit 10	Bit 9	Bit 8	Bit 7	Bit 6	Bit 5	Bit 4	Bit 3	Bit 2	Bit 1	LSB	1	X	X

D0–D1: Undefined. TRI-STATE will be output on SI/0.

D2: High.

D3–D15: Temperature Data. One LSB = 0.0625°C. Two's complement format.

#### 1.5.4 Manufacturer's Device ID Register

(Read Only):

D15	D14	D13	D12	D11	D10	D9	D8	D7	D6	D5	D4	D3	D2	D1	D0
1	0	0	0	0	0	0	0	0	0	0	0	0	0	X	X

D0–D1: Undefined. TRI-STATE will be output on SI/0.

D2–D15: Manufacturer's/Device ID Data. This register is accessed whenever the LM74 is in shutdown mode.

## 2.0 Serial Bus Timing Diagrams

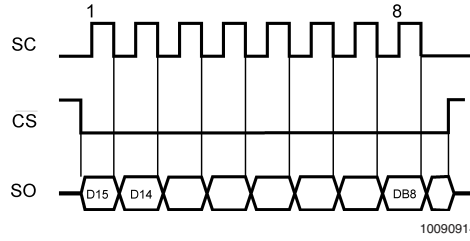

a) Reading Continuous Conversion - Single Eight-Bit Frame

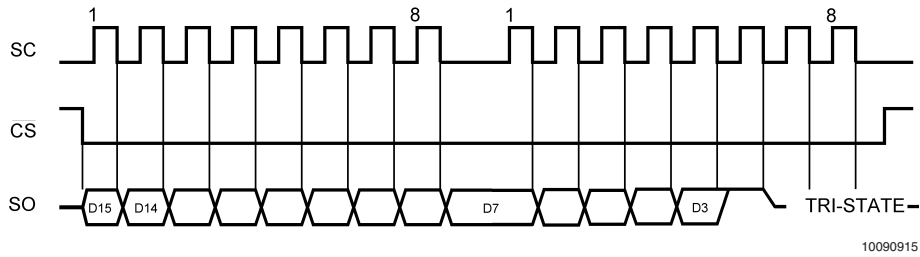

b) Reading Continuous Conversion - Two Eight-Bit Frames

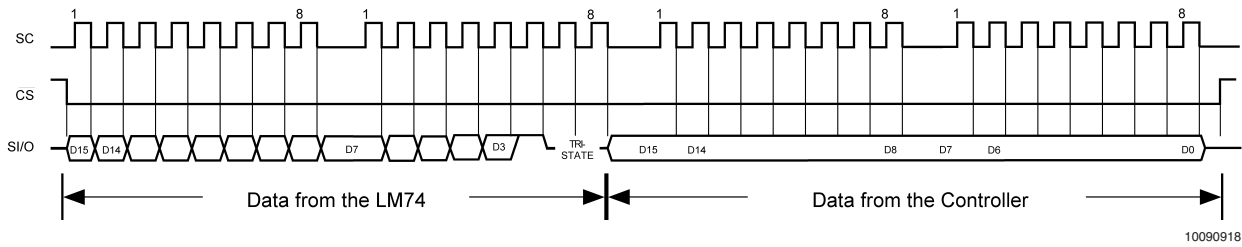

c) Writing Shutdown Control

FIGURE 7. Timing Diagrams

### 3.0 Application Hints

To get the expected results when measuring temperature with an integrated circuit temperature sensor like the LM74, it is important to understand that the sensor measures its own die temperature. For the LM74, the best thermal path between the die and the outside world is through the LM74's pins. In the SO-8 package all the pins on the LM74 will have an equal effect on the die temperature. Because the pins represent a good thermal path to the LM74 die, the LM74 will provide an accurate measurement of the temperature of the printed circuit board on which it is mounted. There is a less efficient thermal path between the plastic package and the LM74 die. If the ambient air temperature is significantly different from the printed circuit board temperature, it will have a small effect on the measured temperature.

In probe-type applications, the LM74 can be mounted inside a sealed-end metal tube, and can then be dipped into a bath or screwed into a threaded hole in a tank. As with any IC, the LM74 and accompanying wiring and circuits must be kept insulated and dry, to avoid leakage and corrosion. This is especially true if the circuit may operate at cold temperatures

### 4.0 Typical Applications

where condensation can occur. Printed-circuit coatings and varnishes such as Humiseal and epoxy paints or dips are often used to insure that moisture cannot corrode the LM74 or its connections.

#### 3.1 micro SMD LIGHT SENSITIVITY

The LM74 in the micro SMD package should not be exposed to ultraviolet light. The micro SMD package does not completely encapsulate the LM74 die in epoxy. Exposing the LM74 micro SMD package to bright sunlight will not immediately cause a change in the output reading. Our experiments show that directly exposing the circuit side (bump side) of the die to high intensity ( $\geq 1\text{mW/cm}^2$ ) ultraviolet light, centered at a wavelength of 254nm, for greater than 20 minutes will deprogram the EEPROM cells in the LM74. Since the EEPROM is used for storing calibration coefficients, the LM74 will function but the temperature accuracy will no longer be as specified. Light can penetrate through the side of the package as well, so exposure to ultra violet radiation is not recommended even after mounting.

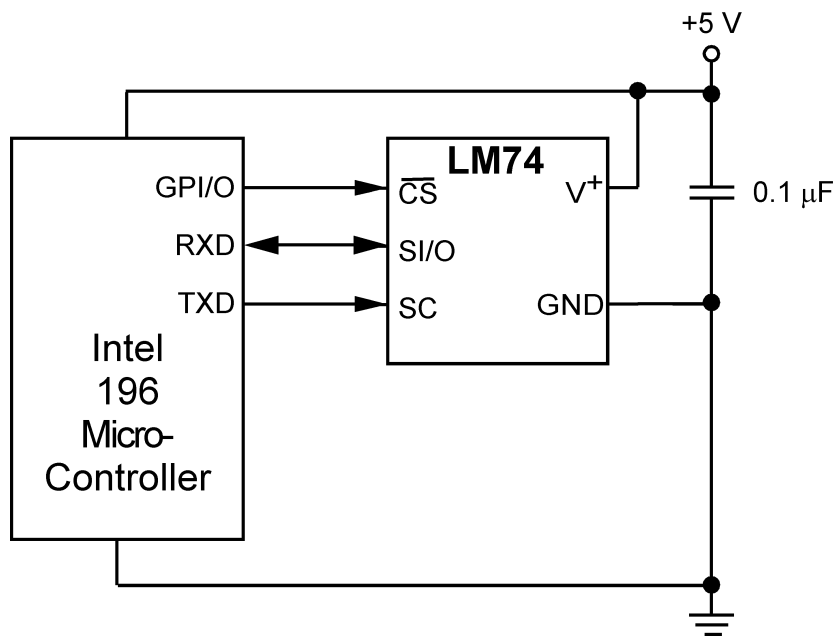

10090920

FIGURE 8. Temperature monitor using Intel 196 processor

## 4.0 Typical Applications (Continued)

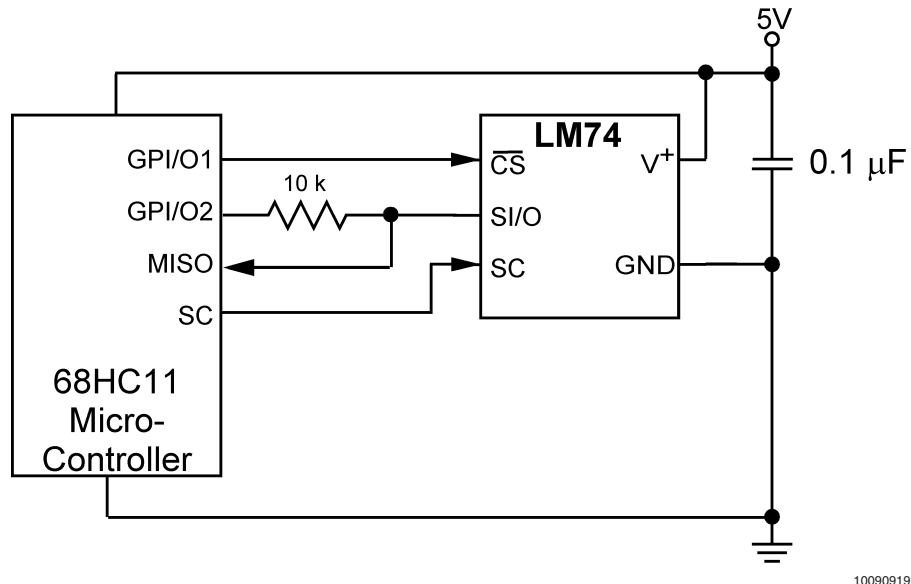

10090919

FIGURE 9. LM74 digital input control using micro-controller's general purpose I/O.

**Physical Dimensions** inches (millimeters) unless otherwise noted

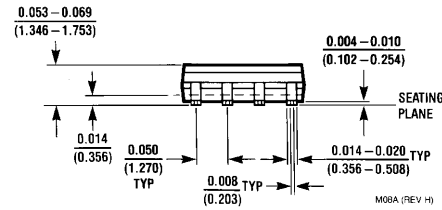
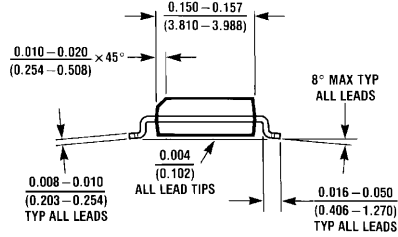
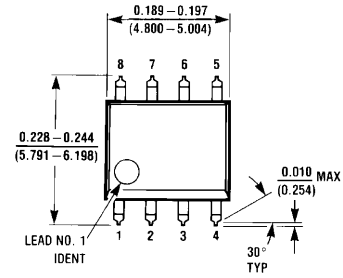

**8-Lead Molded Small Outline Package**  
**Order Number LM74CIM-3, LM74CIMX-3, LM74CIM-5 or LM74CIMX-5**  
**NS Package Number M08A**

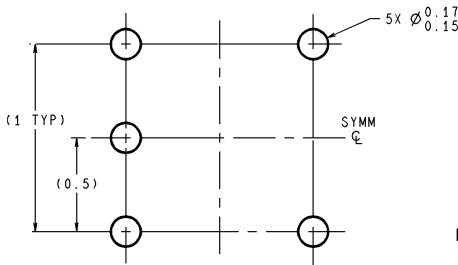

**LAND PATTERN RECOMENDATION**

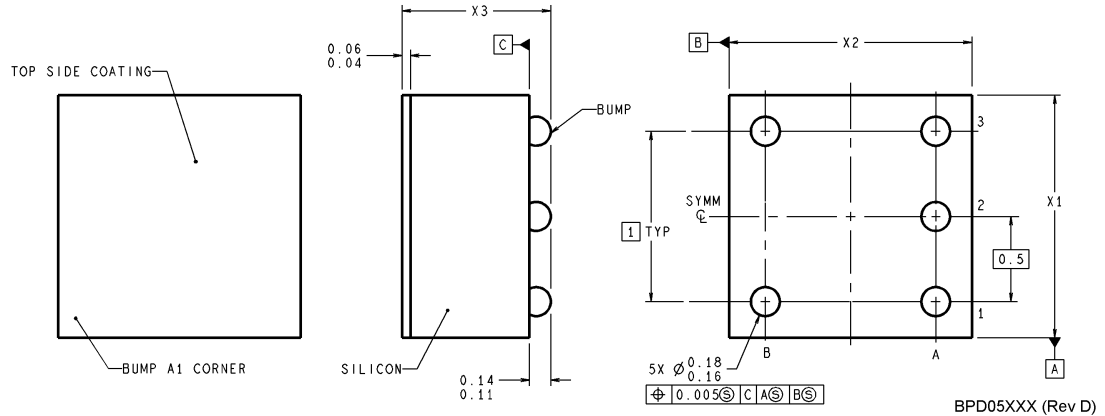

**5-Bump micro SMD Ball Grid Array Package**  
**Order Number LM74CIBP-3, LM74CIBPX-3, LM74CIBP-5, LM74CIBPX-5**  
**NS Package Number BPD05MPB**  
 The following dimensions apply to the BPD05MPB package  
 shown above: X1=1565µm ±30µm, X2=1615µm ±30µm, X3=850µm ±50µm.

## Notes

### LIFE SUPPORT POLICY

NATIONAL'S PRODUCTS ARE NOT AUTHORIZED FOR USE AS CRITICAL COMPONENTS IN LIFE SUPPORT DEVICES OR SYSTEMS WITHOUT THE EXPRESS WRITTEN APPROVAL OF THE PRESIDENT AND GENERAL COUNSEL OF NATIONAL SEMICONDUCTOR CORPORATION. As used herein:

1. Life support devices or systems are devices or systems which, (a) are intended for surgical implant into the body, or (b) support or sustain life, and whose failure to perform when properly used in accordance with instructions for use provided in the labeling, can be reasonably expected to result in a significant injury to the user.
2. A critical component is any component of a life support device or system whose failure to perform can be reasonably expected to cause the failure of the life support device or system, or to affect its safety or effectiveness.

### BANNED SUBSTANCE COMPLIANCE

National Semiconductor certifies that the products and packing materials meet the provisions of the Customer Products Stewardship Specification (CSP-9-111C2) and the Banned Substances and Materials of Interest Specification (CSP-9-111S2) and contain no "Banned Substances" as defined in CSP-9-111S2.



**National Semiconductor**  
**Americas Customer**  
**Support Center**  
 Email: new.feedback@nsc.com  
 Tel: 1-800-272-9959

**National Semiconductor**  
**Europe Customer Support Center**  
 Fax: +49 (0) 180-530 85 86  
 Email: europe.support@nsc.com  
 Deutsch Tel: +49 (0) 69 9508 6208  
 English Tel: +44 (0) 870 24 0 2171  
 Français Tel: +33 (0) 1 41 91 8790

**National Semiconductor**  
**Asia Pacific Customer**  
**Support Center**  
 Email: ap.support@nsc.com

**National Semiconductor**  
**Japan Customer Support Center**  
 Fax: 81-3-5639-7507  
 Email: jpn.feedback@nsc.com  
 Tel: 81-3-5639-7560

www.national.com