

## SINGLE-PHASE BRIDGE RECTIFIER

**DF005 THRU DF10  
DB101 THRU DB107**

**VOLTAGE RANGE**

**50 to 1000 Volts**

**CURRENT**

**1.0 Ampere**

### FEATURES

- Glass passivated chip junction
- High forward surge current capability
- Ideal for printed circuit board
- High temperature soldering guaranteed:  
260°C/10 seconds at terminals

### MECHANICAL DATA

- Case: Transfer molded plastic
- Epoxy: UL94V-0 rate flame retardant
- Terminals solderable per MIL-STD-202E method 208C
- Polarity: Molded on body
- Mounting position: Any
- Weight: 0.04 ounce, 1.0 gram

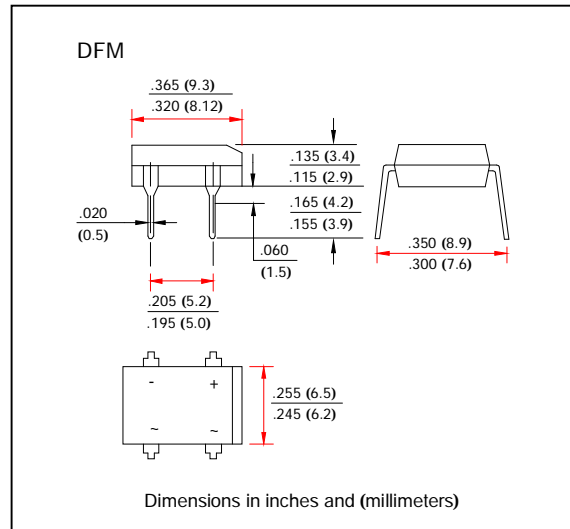

### MAXIMUM RATINGS AND ELECTRICAL CHARACTERISTICS

- Ratings at 25°C ambient temperature unless otherwise specified
- Single Phase, half wave, 60Hz, resistive or inductive load
- For capacitive load derate current by 20%

	SYMBOLS	DF005 DB101	DF01 DB102	DF02 DB103	DF04 DB104	DF06 DB105	DF08 DB106	DF10 DB107	UNIT	
Maximum Reverse Peak Repetitive Voltage	$V_{RRM}$	50	100	200	400	600	800	1000	Volts	
Maximum RMS Voltage	$V_{RMS}$	35	70	140	280	420	560	700	Volts	
Maximum DC Blocking Voltage	$V_{DC}$	50	100	200	400	600	800	1000	Volts	
Maximum Average Forward Rectified Output Current, 0.06" (1.5mm) lead length at $T_A=40^\circ\text{C}$ (Note 2)	$I_{(AV)}$	1.0							Amps	
Peak Forward Surge Current 8.3ms single half sine wave superimposed on rated load (JEDEC Method)	$I_{FSM}$	50							Amps	
Rating for Fusing ( $t < 8.3\text{ms}$ )	$I^2t$	10							$\text{A}^2\text{s}$	
Maximum Instantaneous Forward Voltage drop Per Bridge element 1.0A	$V_F$	1.1							Volts	
Maximum Reverse Current at rated DC blocking voltage per element	$T_A=25^\circ\text{C}$	$I_R$							5	$\mu\text{Amps}$
	$T_A=125^\circ\text{C}$								0.5	mAmps
Typical Junction Capacitance (Note 1)	$C_J$	25							pF	
Typical Thermal Resistance (Note 2)	$R_{\theta JA}$	40							$^\circ\text{C}/\text{W}$	
Operating and Storage Temperature Range	$T_J, T_{STG}$	-55 to +150							$^\circ\text{C}$	

- Notes:**
1. Measured at 1.0MHz and applied reverse voltage of 4.0 Volts.
  2. Unit mounted on P.C.B. with 0.51" x 0.51" ( 13x13mm) copper pads.

# SINGLE-PHASE BRIDGE RECTIFIER

**DF005 THRU DF10  
DB101 THRU DB107**

**VOLTAGE RANGE**                      50 to 1000 Volts  
**CURRENT**                                      1.0 Ampere

## RATINGS AND CHARACTERISTIC CURVES DF005 THRU DF10 DB101 THRU DB107

**FIG. 1- DERATING CURVE FOR OUTPUT RECTIFIED CURRENT**

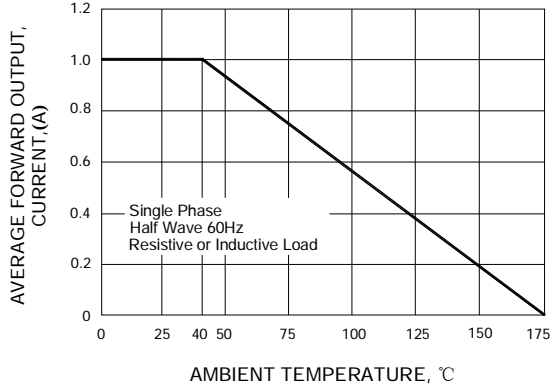

**FIG. 2- MAXIMUM NON-REPETITIVE PEAK FORWARD SURGE CURRENT PER ELEMENT**

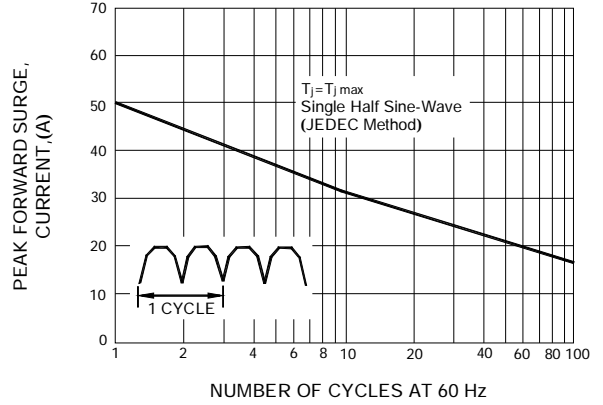

**FIG. 3- TYPICAL FORWARD CHARACTERISTICS PER BRIDGE ELEMENT**

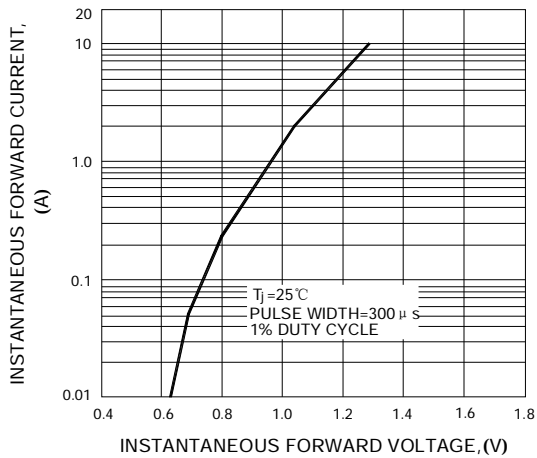

**FIG. 4- TYPICAL REVERSE CHARACTERISTICS PER BRIDGE ELEMENT**

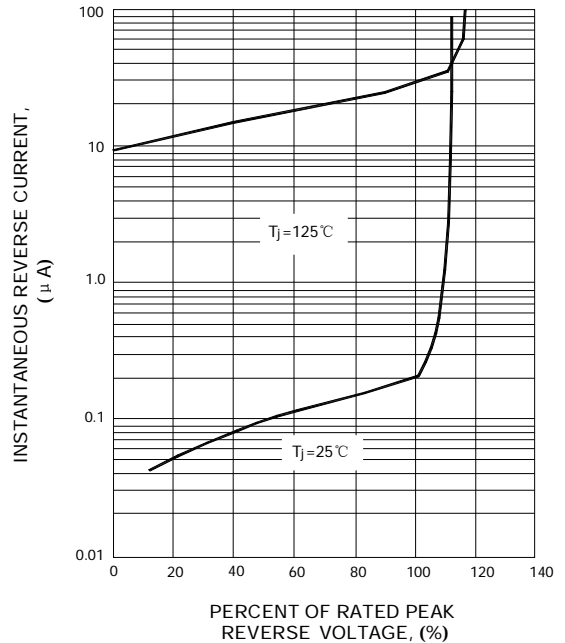

**FIG. 5- TYPICAL JUNCTION CAPACITANCE PER BRIDGE ELEMENT**

