

Transient Voltage Suppressors

SMAJ Series

Transient Voltage Suppressors - SMAJ Series

Features

1. Halogen-free
2. Rohs compliant
3. Typical maximum temperature coefficient
4. $\Delta V_{BR}=0.1\% \times V_{BR}@25^{\circ}\text{C} \times \Delta T$
5. Glass passivated Chip junction in DO-214AC package
6. 800W peak pulse capadility at 10x1000 μs waveform, repetition rate (duty cycles):0.01%
7. Fast response time:typically less than 1.0ps from 0 Volts to BV min
8. Excellent clamping capability
9. Low incremental surge resistance
10. Typical IR less than 5 μA above 11V
11. High temperature soldering guaranteed: 260 $^{\circ}\text{C}$ /40 seconds / 0.375", (9.5mm) lead length, 5lbs., (2.3kg)tension
12. Plastic package has underwriters laboratory flammability classification 94v-0

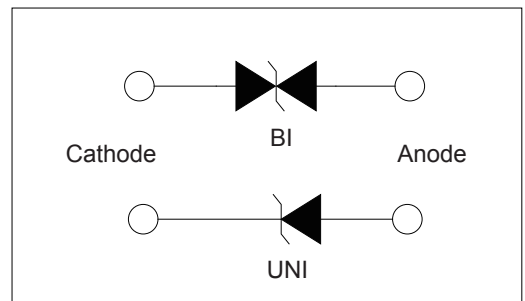
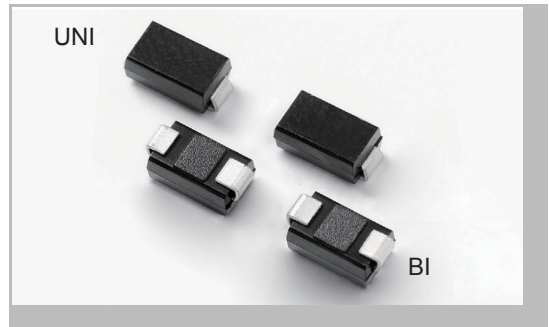

Applications

TVS devices are ideal for the protection of I/O interfaces,VCC bus and other vulnerable circuits used in telecom, computer, industrial and consumer electronic applications.

Mechanical Characteristics

Rating	Symbol	Value	Units
Peak Pulse Power Dissipation at TA=25 $^{\circ}\text{C}$ by 10x1000 μs test waveform (Fig.1)(Note 1),(Note 2)	P_{PPM}	600	Watts
Power Dissipation on infinite heat sink at TA=50 $^{\circ}\text{C}$	P_D	3.3	Watts
Peak Forward Surge Current, 8.3ms Single Half Sine Wave(Note 3)	I_{FSM}	40	Amps
Maximum Instantaneous Forward Voltage at 25A for Unidirectional only (Note 4)	V_F	3.5/5.0	V
Operating junction and Storage Temperature Range.	T_J, T_{STG}	-55 $^{\circ}\text{C}$ to 150 $^{\circ}\text{C}$	$^{\circ}\text{C}$
Typical Thermal Resistance Junction to Lead	$R_{\omega JL}$	30	$^{\circ}\text{C}/\text{W}$
Typical Thermal Resistance Junction to Ambient	$R_{\omega JA}$	150	$^{\circ}\text{C}/\text{W}$

Notes:

1. Non-repetitive current pulse , per Fig. 3 and derated above TA = 25 $^{\circ}\text{C}$ per Fig. 2.
2. Measured on 8.3ms single half sine wave or equivalent square wave, duty cycle=4 perminute maximum.
3. $V_F < 3.5\text{V}$ for devices of $V_{BR} \leq 200\text{V}$ and $V_F < 5.0\text{V}$ for devices of $V_{BR} \geq 201\text{V}$.

Electrical Characteristics

Type Number		Device Marking Code		Reverse Stand-Off Voltage	Breakdown Voltage@I _T		Test Current	Maximum Clamping Voltage@I _{pp}	Peak Pulse Current	Reverse Leakage @V _{RWM}
(UNI)	(BI)	UNI	BI	V _{RWM} (V)	V _{BR MIN.} (V)	(V)	I _T (mA)	V _C (V)	I _{pp} (A)	I _R (μA)
SMAJ5.0A	SMAJ5.0CA	HE	TE	5.0	6.40	7.25	10	9.2	43.5	800
SMAJ6.0A	SMAJ6.0CA	HG	TG	6.0	6.67	7.67	10	10.3	38.8	800
SMAJ6.5A	SMAJ6.5CA	HK	TK	6.5	7.22	8.30	10	11.2	35.7	500
SMAJ7.0A	SMAJ7.0CA	HM	TM	7.0	7.78	8.95	10	12.0	33.3	200
SMAJ7.5A	SMAJ7.5CA	HP	TP	7.5	8.33	9.58	1	12.9	31.0	100
SMAJ8.0A	SMAJ8.0CA	HR	TR	8.0	8.89	10.23	1	13.6	29.4	50
SMAJ8.5A	SMAJ8.5CA	HT	TT	8.5	9.44	10.82	1	14.4	27.7	20
SMAJ9.0A	SMAJ9.0CA	HV	TV	9.0	10.00	11.50	1	15.4	26.0	10
SMAJ10A	SMAJ10CA	HX	TX	10.0	11.10	12.80	1	17.0	23.5	5
SMAJ11A	SMAJ11CA	HZ	TZ	11.0	12.20	14.00	1	18.2	22.0	5
SMAJ12A	SMAJ12CA	IE	UE	12.0	13.30	15.30	1	19.9	20.1	5
SMAJ13A	SMAJ13CA	IG	UG	13.0	14.40	16.50	1	21.5	18.6	5
SMAJ14A	SMAJ14CA	IK	UK	14.0	15.60	17.90	1	23.2	17.2	5
SMAJ15A	SMAJ15CA	IM	UM	15.0	16.70	19.20	1	24.4	16.4	5
SMAJ16A	SMAJ16CA	IP	UP	16.0	17.80	20.50	1	26.0	15.3	5
SMAJ17A	SMAJ17CA	IR	UR	17.0	18.90	21.70	1	27.6	14.5	5
SMAJ18A	SMAJ18CA	IT	UT	18.0	20.00	23.30	1	29.2	13.7	5
SMAJ20A	SMAJ20CA	IV	UV	20.0	22.20	25.50	1	32.4	12.3	5
SMAJ22A	SMAJ22CA	IX	UX	22.0	24.40	28.00	1	35.5	11.2	5
SMAJ24A	SMAJ24CA	IZ	UZ	24.0	26.70	30.70	1	38.9	10.3	5
SMAJ26A	SMAJ26CA	JE	VE	26.0	28.90	33.20	1	42.1	9.5	5
SMAJ28A	SMAJ28CA	JG	VG	28.0	31.10	35.80	1	45.4	8.8	5
SMAJ30A	SMAJ30CA	JK	VK	30.0	33.30	38.30	1	48.4	8.3	5
SMAJ33A	SMAJ33CA	JM	VM	33.0	36.70	42.20	1	53.3	7.5	5
SMAJ36A	SMAJ36CA	JP	VP	36.0	40.00	46.00	1	58.1	6.9	5
SMAJ40A	SMAJ40CA	JR	VR	40.0	44.40	51.10	1	64.5	6.2	5
SMAJ43A	SMAJ43CA	JT	VT	43.0	47.80	54.90	1	69.4	5.7	5
SMAJ45A	SMAJ45CA	JV	VV	45.0	50.00	57.50	1	72.7	5.5	5
SMAJ48A	SMAJ48CA	JX	VX	48.0	53.30	61.30	1	77.4	5.2	5
SMAJ51A	SMAJ51CA	JZ	VZ	51.0	56.70	65.20	1	82.4	4.9	5
SMAJ54A	SMAJ54CA	RE	WE	54.0	60.00	69.00	1	87.1	4.6	5
SMAJ58A	SMAJ58CA	RG	WG	58.0	64.40	74.10	1	93.6	4.3	5
SMAJ60A	SMAJ60CA	RK	WK	60.0	66.70	76.70	1	96.8	4.1	5
SMAJ64A	SMAJ64CA	RM	WM	64.0	71.10	81.80	1	103.0	3.9	5
SMAJ70A	SMAJ70CA	RP	WP	70.0	77.80	89.50	1	113.0	3.5	5
SMAJ75A	SMAJ75CA	RR	WR	75.0	83.30	95.80	1	121.0	3.3	5
SMAJ78A	SMAJ78CA	RT	WT	78.0	86.70	99.70	1	126.0	3.2	5
SMAJ85A	SMAJ85CA	RV	WV	85.0	94.40	108.20	1	137.0	2.9	5
SMAJ90A	SMAJ90CA	RX	WX	90.0	100.00	115.50	1	146.0	2.7	5
SMAJ100A	SMAJ100CA	RZ	WZ	100.0	111.00	128.00	1	162.0	2.5	5
SMAJ110A	SMAJ110CA	SE	XE	110.0	122.00	140.50	1	177.0	2.3	5
SMAJ120A	SMAJ120CA	SG	XG	120.0	133.00	153.00	1	193.0	2.0	5
SMAJ130A	SMAJ130CA	SK	XK	130.0	144.00	165.50	1	209.0	1.9	5
SMAJ150A	SMAJ150CA	SM	XM	150.0	167.00	192.60	1	243.0	1.6	5
SMAJ160A	SMAJ160CA	SP	XP	160.0	178.00	205.00	1	259.0	1.5	5
SMAJ170A	SMAJ170CA	SR	XR	170.0	189.00	217.50	1	275.0	1.4	5
SMAJ180A	SMAJ180CA	ST	XT	180.0	198.00	230.40	1	292.0	1.3	5
SMAJ190A	SMAJ190CA	SV	XV	190.0	209.00	243.20	1	308.0	1.3	5
SMAJ200A	SMAJ200CA	SX	XX	200.0	220.00	256.00	1	324.0	1.2	5
SMAJ210A	SMAJ210CA	SZ	XZ	210.0	231.00	268.80	1	340.0	1.2	5
SMAJ220A	SMAJ220CA	ZE	YE	220.0	242.00	281.60	1	356.0	1.1	5
SMAJ250A	SMAJ250CA	ZG	YG	250.0	279.00	309.00	1	405.0	1.0	5
SMAJ300A	SMAJ300CA	ZK	YK	300.0	335.00	371.00	1	486.0	0.8	5

Transient Voltage Suppressors - SMAJ Series

Ratings and Characteristic Curves

Figure 1 - Peak Pulse Power Rating Curve

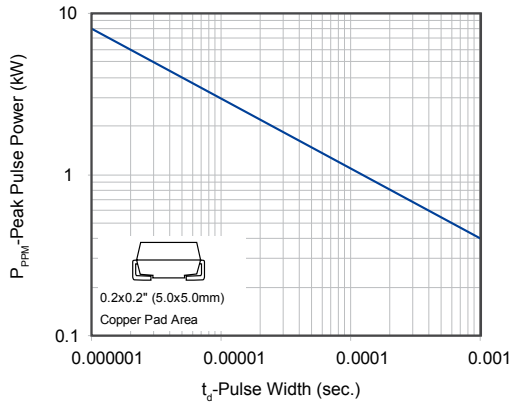

Figure 2 - Pulse Derating Curve

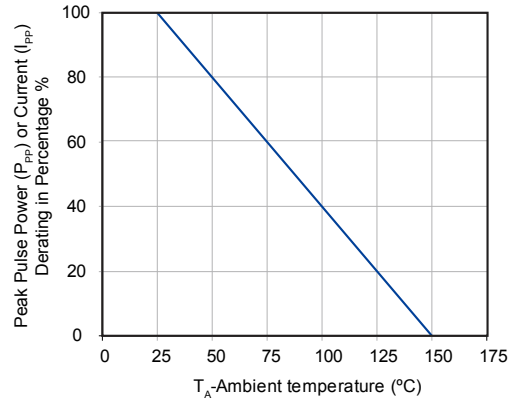

Figure 3 - Pulse Waveform

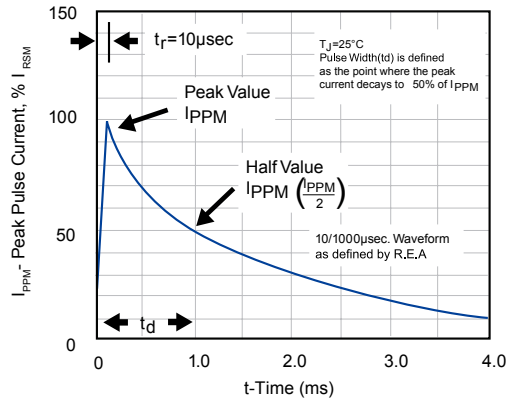

Figure 4 - Typical Junction Capacitance

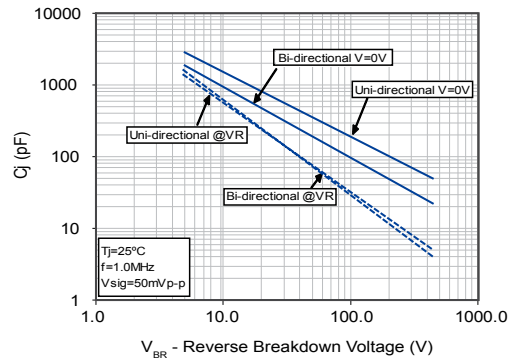

Figure 5 - Steady State Power Derating Curve

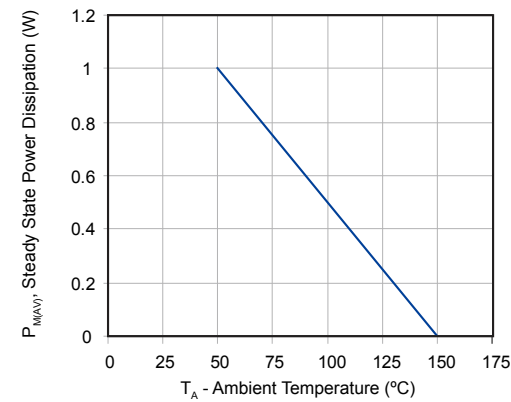
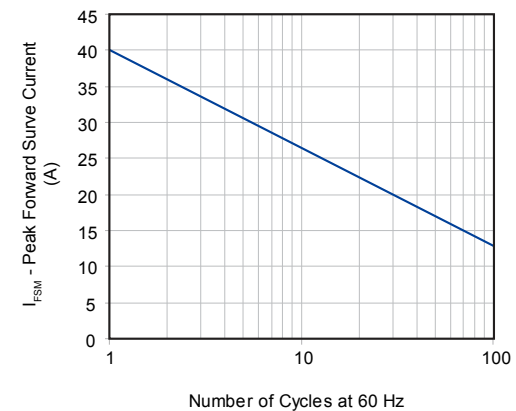

Figure 6 - Maximum Non-Repetitive Peak Forward Surge Current



Transient Voltage Suppressors - SMAJ Series

Soldering Parameters

	Flow Condition	Lead-free assembly
Pre Heat	- Temperature Min ($T_{s(min)}$)	150°C
	- Temperature Max ($T_{s(max)}$)	200°C
	- Time (min to max) (t_s)	60-180 secs
Average ramp up rate (Liquidus Temp (T_L) to peak)		3°C/second max
$T_{s(max)}$ to T_L - Ramp-up Rate		3°C/second max
Reflow	- Temperature (T_L) (Liquidus)	217°C
	- Time (min to max) (t_s)	60-150 seconds
Peak Temperature (T_p)		260 ^{+0/-5} °C
Time within 5°C of actual peak Temperature (t_p)		20-40 seconds
Ramp-down Rate		6°C/second max
Time 25°C to peak Temperature (T_p)		8 minutes Max.
Do not exceed		280°C

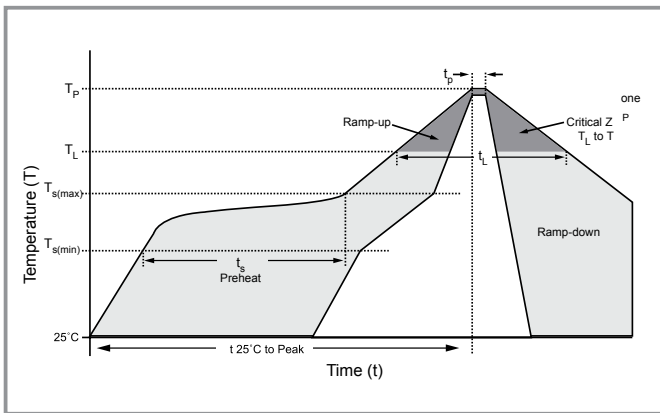

Physical Specifications

Weight	0.002 ounce, 0.061 gram
Case	JEDEC DO-214AC molded plastic body over passivated junction.
Polarity	Color band denotes the cathode except Bipolar.
Termina	Matte Tin axial leads, solderable per JESD22-B102D.

Environmental Specifications

Temperature Cycle	JESD22-A104
Pressure Cooker	JESD 22-A102
High Temp. Storage	JESD22-A103
HTRB	JESD22-A108
Thermal Shock	JESD22-A106

Transient Voltage Suppressors - SMAJ Series

Dimensions

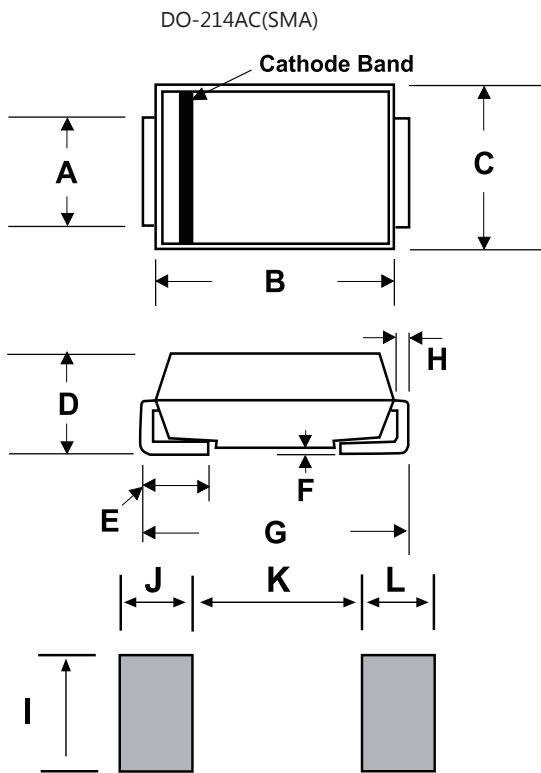

Unit:mm

DIM	Inches		Millimeters	
	Min	Max	Min	Max
A	0.049	0.065	1.250	1.650
B	0.157	0.177	3.990	4.500
C	0.100	0.110	2.540	2.790
D	0.078	0.090	1.980	2.290
E	0.030	0.060	0.780	1.520
F	-	0.008	-	0.203
G	0.194	0.208	4.930	5.280
H	0.006	0.012	0.152	0.305
I	0.070	-	1.800	-
J	0.082	-	2.100	-
K	-	0.090	-	2.300
L	0.082	-	2.100	-

Part Numbering System

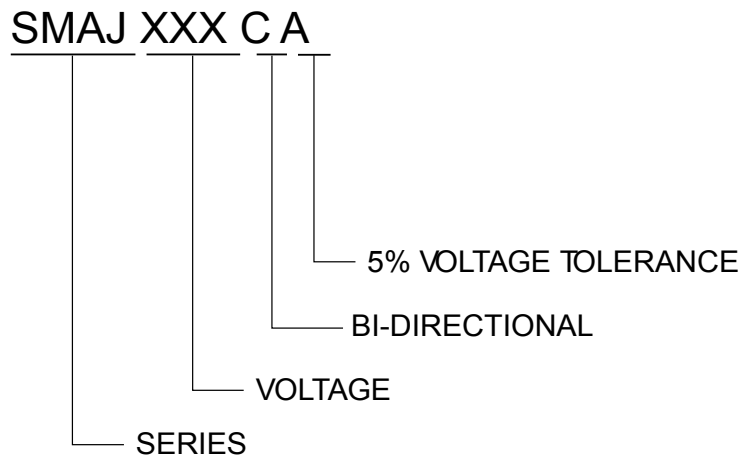

Transient Voltage Suppressors - SMAJ Series

Packaging

Part Number	Component Package	Quantity	Packaging Option	Packaging Specification
SMAJxxxXX	DO-214AC	2000	Tape&Reel - 7' tape	EIA RS-481

Warehouse Storage Conditions of Products

- Storage Conditions:
 1. Storage Temperature: -10°C~+40°C
 2. Relative Humidity:≤75%RH
 3. Keep away from corrosive atmosphere and sunlight.
- Period of Storage: 1 year